

**15-Ton Max. Capacity
Under 8 Feet Wide**

- Rated Capacity Limiter ... Standard
- Capacity on Outriggers ... 30,000 lbs
- Pick and Carry Capacity ... up to 17,000 lbs
- Height ... 8'
- Width ... 7' 10-1/2"
- Boom Rotation ... 360 Degree Continuous
- Sheave Height ... up to 73' 8"
- Horizontal Reach ... up to 66'
- 4-Wheel Steer ... Standard
- 4-Wheel Drive ... Optional
- Powershift Transmission ... Standard
- Fully Hydraulic Controls for Smooth Precise Operations
- Independent Outrigger Controls
- Dual Fuel Standard, Diesel Optional

BRODERSON
Manufacturing Corp



IC-200-3H

LOAD RADIUS FEET	CAPACITIES IN POUNDS FOR OPERATION ON FIRM LEVEL SURFACE							
	MAIN BOOM ONLY				BOOM EXTENSION			
	ON RUBBER		ON OUTRIGGERS		ON RUBBER		ON OUTRIGGERS	
	360°	FRONT	360°	FRONT	360°	FRONT	360°	FRONT
6	16000	16400	30000	30000	---	---	---	---
8	12500	13000	22400	22400	---	---	---	---
10	10000	10500	18500	18500	7500	7500	7500	7500
12	8050	8700	15700	15700	7500	7500	7500	7500
14	6500	7200	13500	13500	7500	7500	7500	7500
16	5300	6200	10800	10800	6150	7500	7500	7500
18	4450	5400	9550	9550	5000	6450	7500	7500
20	3700	4700	8550	8550	4200	5400	7500	7500
22	3150	4200	7700	7700	3550	4650	6850	6850
24	2650	3700	6950	6950	3050	4000	6250	6250
26	2300	3200	6300	6350	2650	3500	5750	5750
28	1950	2800	5550	5800	2300	3100	5300	5300
30	1700	2450	4800	5300	2000	2700	4900	4900
32	1450	2150	4200	4900	1700	2400	4550	4550
34	1250	1850	3700	4500	1500	2100	4250	4250
38	900	1300	2950	3850	1150	1650	3500	3750
42	650	950	2400	3350	850	1300	2950	3350
46	400	650	1850	2900	600	1050	2450	2950
50	0	550	1750	2500	400	800	2050	2600
54	---	---	---	---	0	600	1700	2300
58	---	---	---	---	0	400	1350	2000
62	---	---	---	---	0	300	1150	1750
66	---	---	---	---	0	0	900	1500

BOOM EXT. ANGLE	BOOM EXTENSION - STRAIGHT OR OFFSET							
	MAIN BOOM ANGLE							
	0°	15°	30°	40°	50°	60°	70°	
0°	3000	3100	3450	3900	4650	6000	7500	
15°	---	3000	3000	3000	3000	3700	5000	
30°	---	---	2500	2500	2600	3100	3800	

LOAD RADIUS IS THE HORIZONTAL DISTANCE FROM THE CENTER OF ROTATION OF THE UNLOADED CRANE TO THE VERTICAL LOAD LINE WITH THE LOAD APPLIED.

EXCEEDING CAPACITY RATINGS OR APPLYING SIDE LOADS TO THE BOOM OR BOOM EXTENSION IS MISUSE, IS HAZARDOUS, AND VOIDS WARRANTY.

CAUTION BOOM EXTENSION LOADS MUST NOT EXCEED MAIN BOOM CAPACITY. DO NOT PICK AND CARRY WITH LOADS ON BOOM EXTENSION. CAPACITIES ON OUTRIGGERS ARE 85% OF TIPPING LOADS. CAPACITIES ON RUBBER ARE 75% OF TIPPING LOADS. CAPACITIES BELOW BOLD LINE ARE LIMITED BY TIPPING. OTHER CAPACITIES ARE LIMITED BY STRUCTURAL OR HYDRAULIC CAPABILITY.

BOOM EXTENSION DEDUCT: 400 LBS. WHEN STOWED ON MAIN BOOM.

IC-200-3H Chart

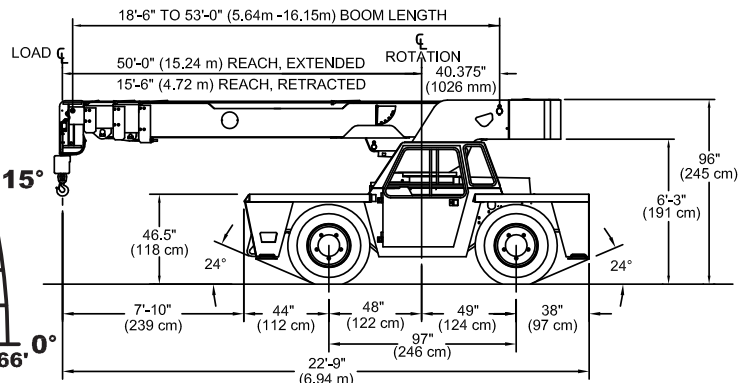
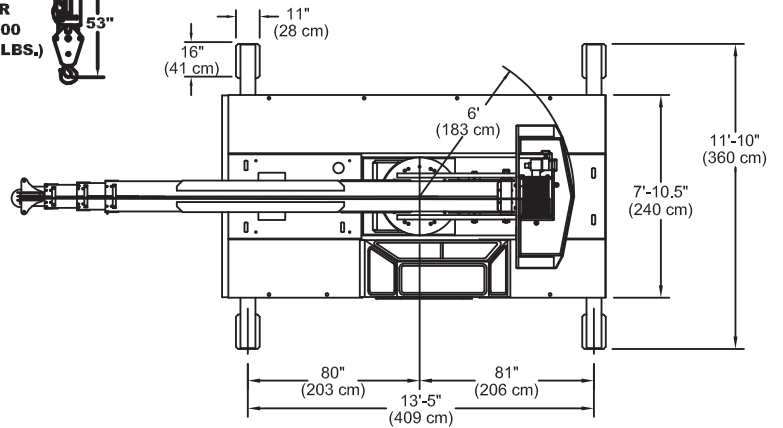
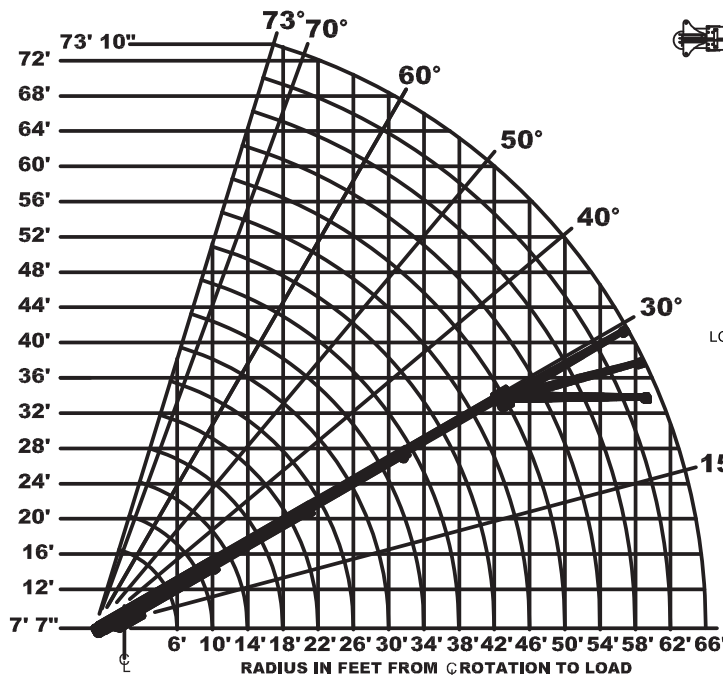
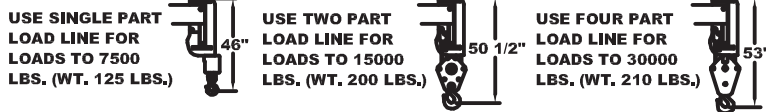
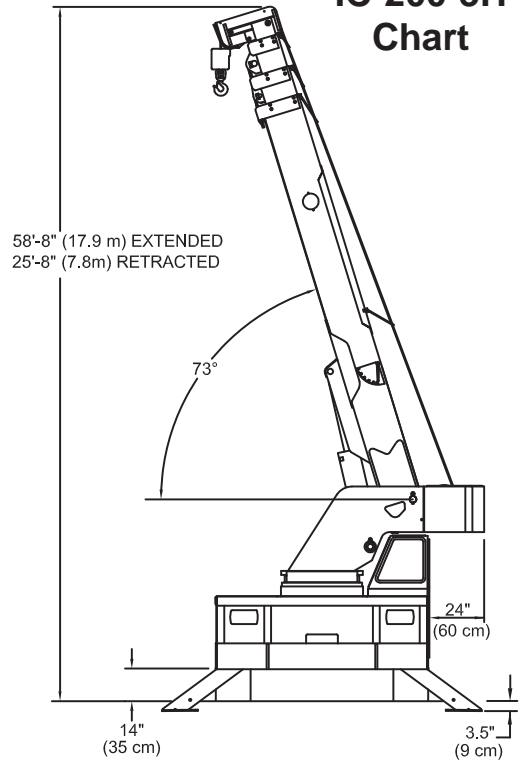

IC-200-H

Specifications

GENERAL:

Weight:	IC-200-2H 28,500 lbs (12,940 kg)	IC-200-3H 31,080 lbs (14,110 kg)
Boom Movement:		
Rotation	Continuous	Continuous
Elevation	0° to 73°	0° to 73°
Extension	21' 0" (6.4m)	34' 6" (10.5m)
Boom Speeds:		
Rotation	1.9 RPM	1.8 RPM
Elevation	20 sec.	20 sec.
Extension	36 sec.	55 sec.
Gradeability:	54% (28 Degrees)	
Turning Radius:	14' 5" (4.42m)	

ENGINE:

	Standard	Optional
Make	GM*	Cummins**
Model	4.3L V-6	QSB3.3
Type	Gasoline	Turbo-Diesel
No. Cyl.	6	4
Displacement	262 CID (4.3L)	199 CID (3.3L)
HP @ Gov. Speed	93 H.P. (69 kW)	100 H.P. (75 kW)
Fuel Tank Capacity	30 Gallons (113L)	

*Electronic Fuel Injection with Dual Fuel & Engine Management System, US EPA Tier 2

**Charge Air Cooled & Grid Heater US EPA Tier 4i Emissions Certified

TRANSMISSION:

Powershift transmission with 4-speeds forward and reverse. Provides powershifts at any engine speed in any gear. All shifting is done with a single lever electrical control mounted on the steering column. Equipped with torque convertor and transmission oil cooler. Torque convertor has stall ratio of 2.2:1.

Gear Ratio:			
First	5.72:1	Second	3.23:1
Third	1.77:1	Fourth	1.00:1

AXLES:

Front Axle:

Planetary drive/steer front axle with 15.78 to 1.0 ratio. Differential equipped with "limited slip" feature. Front axle mounted rigidly to frame.

Gear	Travel Speed	Drawbar Pull*
First	3 MPH	17,000*
Second	5 MPH	8,900*
Third	10 MPH	5,100*
Fourth	18 MPH	2,700*

*Drawbar pull is calculated for GM 4.3L engine.

Rear Axle:

Standard (2-Wheel Drive):

Steering axle with 1-1/2 degree oscillation in either direction.

Optional (4-Wheel Drive):

Planetary drive/steer axle with 24.98 to 1.0 ratio. Differential is not "limited slip" in rear axle. 1-1/2 degree oscillation in either direction. Axle ratio compatible with 4-wheel drive transmission output for front axle match. Transmission equipped with electrohydraulic control for shifting between 2-wheel drive and 4-wheel drive.

STEERING:

Full hydraulic steering unit with two 3-inch (7.6 cm) cylinders attached to each axle. Allows limited steering when engine is not running. A switch on the control panel is used to select rear-wheel steering, four-wheel steering or crab steering. Electronic sensors and control box automatically align the steering when a new mode is selected.

BRAKES:

Service: Split-system, 4-wheel hydraulic-boosted multiple-plate wet disc brakes.

Parking: Hand lever actuated disc-type parking brake on transmission.

TIRES: 15x22.5, 16-ply rating.

OPERATOR COMPARTMENT:

Provides one-position access to all chassis and crane functions. Includes adjustable operator's seat, retracting seat belts, fire extinguisher and bubble level.

CHASSIS:

Cargo Deck:

66 square feet (6 m²) of deck area. 17,000 lbs (7,700 kg) capacity on deck when load is centered over or between axles. Steps located on front corners.

Lifting Rings:

Lifting rings at each corner of load deck so sling can be attached for lifting crane.

Outriggers:

Four hydraulic outriggers of box beam construction with direct-connected holding valves. Independent controls for each outrigger. Outrigger pad dimension: 11" x 16" (28cm x 41cm).

Accessory Storage Box:

Storage box is 14" (35cm) deep x 10-1/2" (26cm) long x 36-1/2" (93cm) wide, located in front cargo deck.

ELECTRICAL:

12 Volt System

Lighting Package:

One pair headlights with high and low beams, tail, brake and turn signal lights and back-up lights in rear, front turn signals and emergency flasher switch at operator's station.

Instrument Package:

Fuel gauge and hourmeter records hours only during actual engine operations. Also includes warning lights for low oil and transmission pressure, check engine, high coolant and transmission temperature, turn signals, high beams, hazard lights, parking brake and four-wheel drive.

Back-Up Alarm:

Provides pulsating sound when transmission is in reverse.

Outrigger Alarm System:

Two-tone alarm is activated when "outrigger down" controls are operated.

HYDRAULIC SYSTEM:

Tandem pump, direct-driven by engine crankshaft, rated at 29 GPM (110 L/min) and 34 GPM (129 L/min) at rated RPM. Hydraulic oil tank capacity of 54 gallons (204 L).

BOOM ASSEMBLY:

Three or four section boom assembly equipped with bearing pads, double-acting hydraulic cylinders with direct-connected holding valves and boom angle indicator on each side of boom.

Boom Rotation:

Heavy-duty ball bearing rotation gear with external teeth. Rotation is powered by hydraulic motor and worm gear drive.

Boom Hoist:

Turret mounted planetary gear hoist hydraulically powered with a baredrum line pull of 10,000 lbs. (4536 kg) at a line speed of 100 FPM (30 m/min). Includes downhaul weight, swivel hook and sheave block for 4-part line and 240 ft (73m) (2H) and 291 ft (89m) (3H) of 1/2" (13mm) hoist rope.

Anti-Two-Block Device:

Prevents damage to hoist rope and/or crane components from pulling load hook against tip.

Sheave Block, Four Part Line:

Double sheave block for 4-part line requirements.

Rated Capacity Limiter:

Warns operator of impending overload with audible and visual signals. Prevents overloads by stopping boom functions that cause overloads.

IC-200-H

Options

Listed below are brief descriptions of options available for this product.
Consult the IC-200-H Engineering Spec for additional information.

MODEL:

IC-200-2H Industrial Crane with
15' 2"-36' 2" (4.6 m-11m) Boom

IC-200-3H Industrial Crane with
15' 6"-50' 0" (4.7m-15.2m) Boom

ENGINE OPTIONS:

Diesel Engine

Cummins QSB3.3 Turbo, Tier 4i

Spark Arrester Muffler

Installed in addition to standard muffler.

Engine Heater

Engine coolant heater installed to circulate warm water through engine, plugs into 120 volt AC.

AXLE & STEERING OPTIONS:

4-Wheel Steer & 2-Wheel Drive

4-Wheel Steer & 4-Wheel Drive

TIRE OPTIONS:

Non-Marking Tires

Foam Filling of Tires

Spare Tire & Wheel

CHASSIS OPTIONS:

Auxiliary Winch

Mounted behind front bumper, hydraulically driven with control in operator's console.

Pintle Hook:

Pintle Hook, Rear

Pintle Hook, Front

Headlight and Taillight Grilles

Welded steel protective grilles for headlights and taillights.

Rearview Mirrors

One mounted on right-hand deck stake and one mounted on left-hand deck stake.

OPERATOR COMPARTMENT OPTIONS:

Operator Guard

Tubular steel weldment with heavy expanded steel mesh top section.

Operator Guard Cover

Clear vinyl cover over Operator Guard, for inclement weather operations.

All Weather Cab

Rigid-mounted canopy section and removable hinged door. Includes heater, electric wind-shield wiper, one sliding glass window in the door and one in the right side of canopy. Defroster fan and dome light included.

Cab Heater Only

Heater with two-speed fan for units without All Weather Cab.

Windshield Washer

Includes reservoir, pump & nozzle.

Floor Mat

Vinyl mat with foam backing.

Operator Suspension Seat

Provides additional comfort for operator.

Noise Reduction Kit

Includes floor mat, control valve cover and side panels of foam backed vinyl for noise reduction.

Air Conditioning

Air Conditioner w/134 coolant.

ELECTRICAL OPTIONS:

Strobe Lights

Yellow strobe light mounted on each side of turret weight box.

Boom Work Lights

One work light mounted to boom to light boom tip and one work light mounted to turret to light ground under boom tip.

Work Lights - Rear

Two work lights recessed in rear bumper.

BOOM ATTACHMENTS:

Boom Extension, 15 Ft. (4.6m) (2H Only)

Swing away and boom stowable.

Boom Extension, 15 Ft. (4.6m), Offsettable (2H Only)

Same as above except the boom extension is offsettable to 3 different positions; 0 degree (inline), 15 degree and 30 degree offset.

Boom Extension, 16 Ft. (5m), Offsettable (3H Only)

Same as above except the boom extension is 16 ft (5m).

Sheave Block - Two-Part Line Searcher Hook:

Nose Mount 5,000 pound (2,268 kg) capacity hook bracket.

Should you require an option or special equipment not listed please consult your dealer salesperson or BMC®.

BRODERSON®

Manufacturing Corp.

14741 West 106th Street

Lenexa, KS 66215 USA

Tel (913) 888-0606

Fax (913) 888-8431

www.bmccranes.com

Dimensions and values shown are for reference purposes only.

Specifications subject to change.

